

common

Overhead Line Corrosion Detector

- PROVIDES EARLY WARNING OF CORROSION DAMAGE
- ENABLES PLANNED REPLACEMENT
- MINIMISES UNEXPECTED FAILURES DUE TO CORROSION
- REDUCES REVENUE LOSS
- REDUCES EMERGENCY REPAIR COSTS
- REDUCES POWER OUTAGES – INCREASES CUSTOMER SATISFACTION
- OPERATES ON ANY SIZE ACSR DEAD LINE
- OPERATES UP TO 275 KV LIVE

Internal Corrosion of ACSR

Internal corrosion is a major factor limiting the life of steel reinforced aluminium conductors (ACSR) and a crucial stage in the corrosion process is the loss of zinc from the central galvanised steel strands. Once this galvanising is lost the aluminium strands are subject to galvanic corrosion and the conductor deteriorates rapidly. The effects of this form of internal corrosion are not visible or detectable by infra-red methods until the conductor is near to failure – too late for the most cost effective action to be taken.

Early Detection is Possible

OHLCD is the only available method for directly detecting this loss of galvanising. This non-destructive inspection technique detects damage long before any degradation is apparent by other non-destructive tests. Early warning of internal corrosion enables the operator to make best use of budgets for reconductoring an ageing network.



Causes of Conductor Corrosion

Corrosion is caused by environmental factors such as time of wetness, industrial pollution or marine salts present in the atmosphere. Severe industrial pollution can sometimes corrode the outside of a conductor, but the loss of cross-section is not usually significant. The more usual and serious form of attack is internal corrosion. This is caused by ingress of pollution and moisture to the interface between the aluminium and steel strands. The galvanising layer on the steel strands provides a degree of protection but preferential corrosion of the zinc eventually exposes the steel so that the aluminium becomes anodic and subject to galvanic corrosion. The attack is worst on the inner aluminium strands and invisible from outside the conductor until the extremely advanced stages when white powder produced by the corroding aluminium can cause visible bulging of the conductor and deterioration of the mechanical properties leading to fracture of the aluminium strands. Once breakages occur, current transfer can cause local overheating and enhanced corrosion leading to failure. The time scale of these events is difficult to quantify but there will usually be a period of several years between the OHLCD detecting significant loss of galvanising and conductor failure: adequate time to implement a least-cost replacement programme.

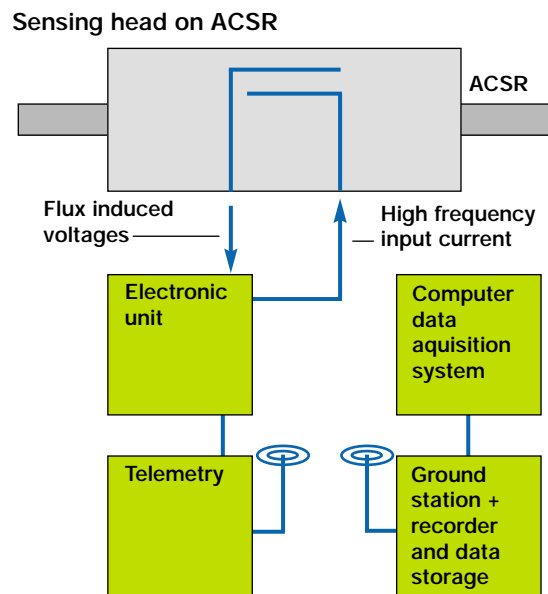

Operating Principle

The OHLCD sensing head is a hollow cylinder which clamps around the conductor. It contains a field winding and a pick-up coil. When a high frequency current is passed through the field winding it generates a magnetic field which penetrates the conductor and induces eddy currents around individual strands.

The alternating flux induces a voltage in the pick-up coil which is processed to give an in-phase and a quadrature output voltage, the magnitudes of which depend on the quality of the galvanised layer. Significant loss of aluminium cross section (5%) is also detectable.

The OHLCD is based on a patented technique developed by The National Grid Technology and Science Division, Leatherhead, England.

Hardware

The detector equipment consists of the sensing head which is connected to a trolley housing the measurement circuitry and distance encoder. This assembly is moved along the conductor by a motorised tug controlled by a radio link. A separate digital radio down link in the measuring trolley transmits the measurements and related distance information to a ground station where it is recorded. Both units are powered by rechargeable batteries.

The groundside hardware consists of the tug controller and a ground station unit connected to a portable PC and a chart recorder. This enables data to be simultaneously inspected and recorded digitally while the survey is in progress.



Tug Control Unit

Software

There are two software packages associated with the OHLCD. The data capture package which is run during measuring operations and an analysis package known as CORAN which is used to analyse the captured data and re-present it in an easily interpreted report format.

Data points colour coded and plotted in the PvQ diagram

Survey run information

Bar chart showing % of line in each corrosion category

Position chart - indicates where corrosion exists along the line

A Typical CORAN Report Page

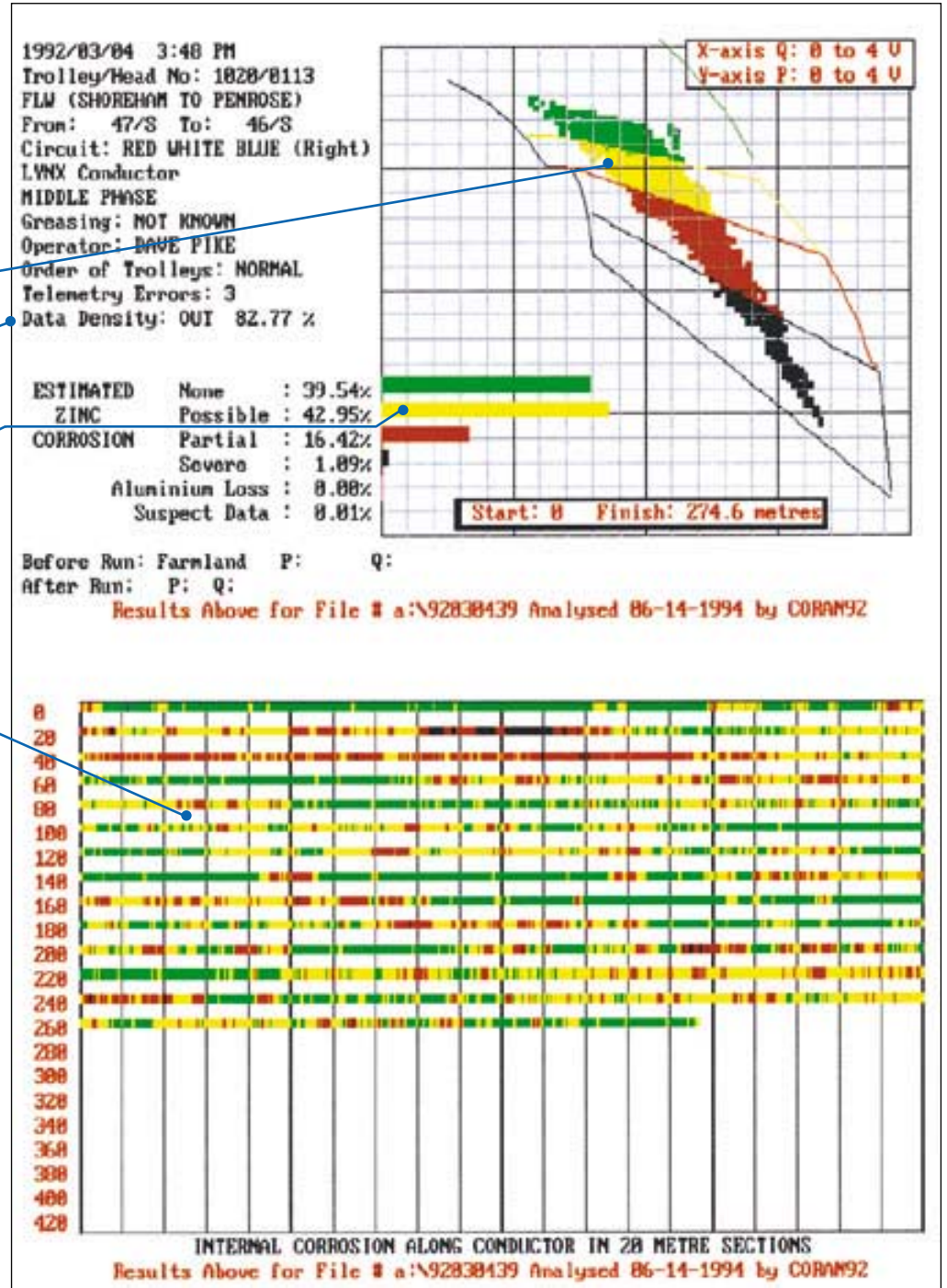

Equipment Capability and Capacity

The OHLCD can be used on any size of ACSR. The standard sensing head will accommodate 10 to 30mm diameter conductor, but special size heads are also available. The largest conductor inspected so far is 56mm diameter.

The original OHLCD was developed for dead-line operation. The more recently developed live-line unit allows inspection of live conductors up to 275 KV. Development work is expected to extend this further.

The time required to inspect a given length of conductor is variable according to access conditions, manpower, weather etc. Typically between 8 and 16 spans of 300 linear metres can be inspected in a normal working day.

Benefits of Condition Assessment Strategy

The real cost benefit of OHLCD surveying derives from the ability to plan maintenance and replacement. Unplanned outages and emergency repairs lose revenue and eat into maintenance budgets. The hard data on conductor condition produced by OHLCD survey allows you to evaluate

the condition of a network, allocate priorities for replacement or repair and implement work to a planned timetable, reducing costs and enhancing quality.

Engineered maintenance solutions win every time over reactive repair strategies.

Ground Station and Data Acquisition



CORMON LTD **C O R R O S I O N** **M O N I T O R I N G** **S Y S T E M S**

Cormon House
Riverbank Business Centre
Old Shoreham Road
Shoreham-by-Sea
West Sussex BN43 5FL U.K.
Tel: +44 (0) 1273 441168
Fax: +44 (0) 1273 441169
email: sales@cormon.com
website: <http://www.cormon.com>



CERT Q5877 • ISO 9001