

Robust Compact Intrinsically Safe Field Instruments



# DCU3 er & lpr data collection units

Data Collection Instruments for Electrical Resistance (ER) or Linear Polarisation Resistance (LPR) and Galvanic (ZRA) monitoring of process corrosion in Hazardous Areas either by battery powered data logging or by remotely powered transmitter

- Data Logging and Transmitting Versions
- Direct to Probe Mounting with Probe Cable Option
- High Resolution Electronics
- Weatherproof Stainless Steel Enclosures
- Lightweight, Low Footprint Design
- ATEX, UL and CSA Approvals

Instrumentation options for most on-line and off-line corrosion and process management applications including hydrocarbon production, refining, petrochemicals and process water systems. The robust stainless steel construction is suitable for the most demanding oilfield conditions including offshore and desert locations.

DCU3 has been designed to minimise the labour and accessories required for installation and commissioning. It provides cost effective tools for almost any basic corrosion management task from real time control to base-line surveillance.

DCU3 is compatible with other CEION® and DCU2 instrumentation and software packages and with all Cormon ER, LPR and Galvanic Probes.





### Electrical Resistance (ER) Monitoring

ER is a simple method of measuring metal loss by comparing the resistance of a corroding/eroding sample and a non-corroding, or protected, reference element of the same material. Any loss of metal from the sample will change its resistance and allow the amount of loss to be calculated. Caution is required in applying ER to depositing sour systems as iron sulphide deposition may impair performance. Application advice is available. Resolution is dependent on the quality of the measuring electronics and the suitability of the sensor or probe. DCU3 instruments make best use of the latest in high performance electronic components and the power of the microprocessor to deliver benchmark quality performance. Consult data sheets GL003 and CMEP 005 for ER probe information.

### Linear Polarisation Resistance (LPR) Monitoring

LPR is a means of determining the corrosivity of a fluid relative to sample electrodes by electrochemical means. While highly responsive to change, the method is restricted to conductive fluids, which limits the number of suitable applications. LPR is popular for cooling water applications but may not be effective where non-conductive deposits, such as oil sludge or scale, are expected. The measurement sequence, which may be anodic, cathodic or bipolar, is controlled by the on-board microprocessor and the result calculated before storage or transmission. LPR units can also be configured to perform galvanic measurements (ZRA) using either LPR or Galvanic probes. This is a specialised measurement sometimes used to indicate changes in oxygen levels in water systems or other process variables. Probe information may be found in datasheets CMEP 020 and GL 0003. Application advice is available.



### Mounting & Mounting Accessories

DCU3 may be directly mounted onto the 6 pin connector of a probe / extension adapter or can be supplied with a probe cable extension to enable wall or pillar mounting. Direct-to-Probe is not recommended for mounting on side or bottom entry probes. For all indirect mounting situations plate mounting brackets in stainless steel are available. In harsh climate areas, particularly desert conditions where steel temperatures may rise above 50°C, an additional sun screen attachment may be specified. This shields the top half of the unit from direct sunlight and creates an air gap to dissipate excessive heat.

### Battery Packs

Sealed battery pack options are offered, including Alkaline, Lithium or Rechargeable cells. Please specify the required type by product code when ordering. Packs are installed by unclamping the container, removing the upper half, locating the pack, connecting the battery to the 9 way socket and replacing the lid.

### Probe Cables

Where the probe cable extensions are ordered the standard supply is PVC covered, screened, blue sheathed, Belden cable. Standard length is 5 meters (16.5 ft). Longer or shorter cables may be requested when ordering. If another cable construction (such as HOFR Armoured type) is required please supply Cormon Sales with a cable specification and length requirement when ordering. In order to maintain measurement quality it is not recommended to extend cables beyond 10meters (33ft).



## Certification

DCU3 is available with ATEX intrinsic safety certification. Certificate ITS05ATEX23471X and UL/CSA listing approval ETL 3074144 to UL Std 913, CAN/CSA Std E60079-0-02 and E60079-11-02.

## Data Logger Upload

The DCU3 is fully compatible with the Cormon model CEI TH hand held data uploader – HHU and HHU-M - datasheet CMEI 022

## Transmitter Hook-up

The transmitter versions include an integral terminal strip and M20 gland access for field cabling to allow hook-up without special tools or connectors. If larger outside diameter cable is used for field cabling an intermediate junction box must be provided. See hook-up data, Page 4 for wiring information.



## Product Codes

| DCU3                            |                        |                                |   |             |  |                                |  |                                      |  |                                     |
|---------------------------------|------------------------|--------------------------------|---|-------------|--|--------------------------------|--|--------------------------------------|--|-------------------------------------|
| Data Collection Unit – Series 3 | Model                  |                                | Type  |             | Accessory 1  |                                | Accessory 2  |                                      | Battery  |                                     |
|                                 | <b>ER</b><br><b>LP</b> | Electrical Resistance          | <b>TD</b>                                     | Transmitter | <b>S</b><br><b>O</b>   | Sun Shield (b)<br>Not Required | <b>M</b><br><b>O</b>   | Mounting Bracket (c)<br>Not Required | Not applicable for transmitters  |                                     |
|                                 |                        | Linear Polarisation Resistance |   | <b>LD</b>   |  | Data Logger (a)                |  | Sun Shield (b)<br>Not Required       | Mounting Bracket (c)<br>Not Required   | <b>PA</b><br><b>PL</b><br><b>PR</b> |
|                                 |                        |                                | a) Hand held upload kit required for LD type. |             | b) Recommended for installations in direct sunlight where steel temperatures may reach 50°C. |                                | c) Only required if used with an extension cable and mounting to wall or plate. Order extension cable separately |                                      | d) Charger unit required for PR type - order model CEA CU. (Includes case and multiple mains adapters). Packs sealed type. |                                     |

| DCU3                            | A         |                                     |   |
|---------------------------------|-----------|-------------------------------------|---|
| Data Collection Unit – Series 3 | Accessory | <b>PA</b><br><b>PL</b><br><b>PR</b> | Alkaline Battery Pack<br>Lithium Battery Pack<br>Rechargeable Battery pack                        |
|                                 |           | <b>MB</b>                           | Mounting Bracket  |
|                                 |           | <b>EP</b>                           | Environmental Protection Box – stainless steel  |
|                                 |           | <b>CB</b>                           | Add length in meters range 01 -10 (1m = 3.3ft)<br>Example - DCU3A CB 03 for 3 meter (±10ft) cable |

# Transmitter Hook-up Data

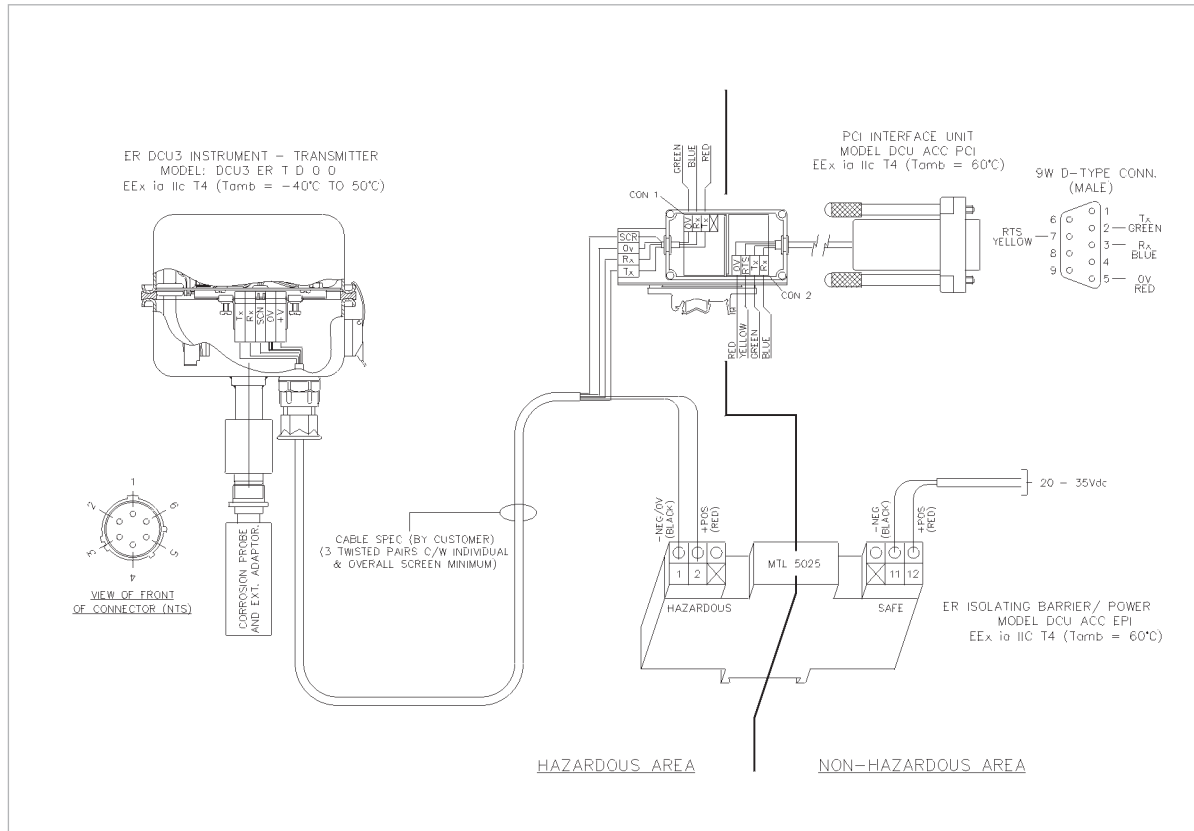

## Specifications

- Temperature (ambient) -40 to +70°C (with sun shield)
- Resolution: ER nominally 0.01% of element thickness  
LPR 0.1% of current & voltage
- Intrinsic Safety: Ex ia IIC T4 (T3 with lithium or rechargeable batteries)
- Dimensions: Housing dia.130mm (max) x 98 high
- Construction: Stainless Steel
- Protection rating IP65
- Logger Capacity: typically 6 months of hourly readings (2048 readings)
- Logging: automatic at settable interval
- Probe cable (standard) extension: 5m (16.5 ft) PVC sheath Belden cable with connectors

## Technical Support

For applications assistance contact the Cormon Flow Assurance Group. Field installation, commissioning and support services are available from our Service group.



Cormon Ltd  
Unit 3, Robell Building  
Chartwell Road, Lancing Business Park  
Lancing, West Sussex BN15 8TU  
United Kingdom

Tel: +44 (0) 1903 854800  
Fax: +44 (0) 1903 854854  
Email: sales@cormon.com

www.cormon.com

LANSING • ABERDEEN • HOUSTON • ABU DHABI • PERTH

