

PROBES FOR STANDARD ACCESS: AC, RC, Fixed and Laboratory

CEION[®] metal loss measurements are made using specially designed intrusive probes. Many CEION[®] applications can make use of the standard probe mounting configurations that are widely used for conventional ER and LPR sensors. These include the 2" high-pressure access fitting (AC series) and the retractable low-pressure system (RC series) as well as thread mounted types.

CEION[®] probes are carefully designed and crafted to ensure that their properties compliment the unique power of the electronics. Metal loss measurement resolution better than 100 times that of conventional ER probes is possible. All CP series probes are compatible with the temperature calculation facilities provided within CEION[®] instrumentation. CEION[®] probes are not interchangeable with ER probes.

This data sheet details the length calculation and product codes for CEION[®] probes in this range. The full range of probes that are available as standard items for these mounting styles is listed. Other mountings and special order items are also available.

SELECTION FOR OPTIMUM PERFORMANCE AND LIFE

In addition to the mounting style it is important to make a careful selection of the probe element thickness to get optimum life and performance. Elements of 20 or 40 mils (0.5 or 1 mm) that would be considered quite thick in ER terms are capable of remarkably fast response to low corrosion rates using CEION[®] technology. Instantaneous response may be ideal for some control applications where a process parameter may be adjusted in real-time but in other cases the time period for making an intervention may be somewhat longer.



In such cases it is cost effective to select a thicker element that responds only a little faster than the optimum intervention period and makes use of the 'spare' capacity of CEION[®] in the form of extended life. It may be possible to match service life to the normal maintenance period and reduce the cost of on-line intervention. A range of ceramic mounted flush and angle head probes has been introduced for severe chemical and temperature environments

Table 1. shows the time to detect 1 and 10 mpy (0.025 and 0.25 mmpy) for various total element thicknesses of flush and tubular element using HR level instruments. The widely accepted convention adopted for ER metal loss probes of sizing elements by the total thickness has been retained for CEION[®] to avoid confusion. As with ER, the usable working life of the element is half of the total thickness. A 40 mil element has 20 mils of usable life.

THICKNESS		FLUSH PROBES		TUBULAR PROBES	
Mils	MM	1 mpy 0.025 mmpy	10 mpy 0.25 mmpy	1 mpy 0.025 mmpy	10 mpy 0.25 mmpy
20	0.5	45 min	5 min	2.5 hrs	15 min
40	1	2 hrs	15 mins	6 hrs	45 min
80	2	6 hrs	35 mins		
160	4	18 hrs	2 hrs		

Table 1. Performance data with HR level instruments
Note: tubular probes of over 40 mils (1mm) are not available in standard mounting styles. Contact Cormon sales for details of flange and hub mounted probes.

PROBE CONSTRUCTION

Body Material: Standard CEION® probe bodies are manufactured from 316 stainless steel with glass sealed connectors.

Element Seal: Flush probes elements are mounted in epoxy or ceramic and tubular elements are welded. Ceramic sealed probes are suitable for a much wider range of process conditions such as high amine concentrations where epoxy settings may be unsuitable. The ceramic sealing process effectively eliminates all edge corrosion effects.

Temperature: Epoxy sealed probes are suitable for 150°C (302°F) and 3600 psi. Ceramic probes are available in Standard 200°C (392°F) and High Temperature 450°C (842°F) versions. Please do not use standard order codes for special performance probes. *Epoxy sealed probes are not suitable for all chemical environments, please check with Cormon sales for advice.*

Welded tubular probes (TW) are suitable for service up to 200°C (392°F) and pressures of 250 bar (3600 psi) or 400 bar (5800 psi) with thicker elements. High temperature tubular probes (TH) are suitable for 500°C (932°F) and 15 bar (217) psi. *The resolution performance of tubular probes is substantially less than for flush/angled head probes of equivalent thickness and they should only be specified where no suitable alternative is possible. Angle head probes may be more suitable for many tasks. Please check with Cormon sales for advice.*

Note:

- 1) Performance temperatures and pressures refer to the probe construction only. Always ensure that the probe mounting method selected is also compatible with service pressure and temperature.
- 2) Intrusive devices exposed to process flow conditions may be subject to vibration induced failure. A simple calculation of Wake and Natural frequencies for the conditions can be performed by Cormon to determine the level of risk. Please contact Cormon sales if you wish to make use of this service.

THE INTELLIGENT PROBE AND COEFFICIENT STRINGS

CEION® is a very sophisticated measurement system that relies on the superb accuracy of the electronic measurement for much of its performance but added resolution is obtained by the precise interpretation of the results in terms of the characteristics of the probe used to make the measurements. CEION® probes are extensively tested and calibrated after manufacturing to ensure that the smallest variation from probe to probe is taken into account. The calibration results in the creation of a multi-digit coefficient string for each individual probe. This is downloaded to the instrument before measurements are made where it is used by the instrument firmware in the final calculation of the metal loss and temperature results.

Cormon has developed I-Probe™ technology that encodes the coefficient string onto a chip that is placed in a separate plug-in module or, for earlier models, in an extension adapter. Some custom probes have this chip built directly into the probe body. Typical 'system' transmitters are configured from the receiver rack and do not require an adapter. If you are ordering a new probe and instrument together you will automatically receive a CPM type probe and a matching configuration module.

IF YOU ARE ORDERING A NEW PROBE FOR AN EXISTING INSTRUMENT PLEASE READ THE FOLLOWING CAREFULLY BEFORE SELECTING THE PRODUCT CODE.

Step1. Check your CEION instrument to see if it has the word ATEX in the certificate number eg: ITS 03 ATEX 21262. If it is 'ATEX', order a probe with code beginning **CPM**. If not, go to Step 2. **NOTE:** If your unit was ex-works after October 2003 it is sure to be ATEX.

Step 2. If the unit is not an ATEX certified unit count the number of connector pins that the probe connector will accept. If this number is 13, order a probe with code beginning **CPE** and an '**M**' type extension adapter. If the number is 6, order a probe with code beginning **CPE** – do not order an adapter as the configuration is done via a PC using the coefficients from the probe documentation. **HELP!** Cormon retain full configuration information for probes and instruments, so providing us with instrument or probe serial numbers will usually allow us to advise you which configuration you have. Other information such as date of purchase or order number is also helpful if available.

ACCESSORY

CPA			
CEION, Probe Accessory	RC	Adapter for all RC and Fixed probes with flanged & threaded connectors	M
	SW	Swagelock Extension Adapter for AC series probes	
	PL	Plain Extension Adapter for AC series probes	
Adapter bodies are 316ss, RC adapters are 120mm long, SW adapters are 206mm long, and PL adapters are 92mm long.			

LENGTH CALCULATION: AC STYLE (HIGH PRESSURE ACCESS) PROBES

Fitting	Probe style Tubular CEION®	Flush/Angle Head CEION®
Standard 5.25" access fitting	$P + W + 32$	$W + 61$
Flanged access fitting	$S + W + P - 102$	$S + W - 73$
S = Total stand off from pipe OD to top of access fitting in mm	P = Projection of device into pipe measured from pipe to tip of probe in mm	W = Wall thickness of pipe in mm

NOTE:
 1) Angle head probes: use the calculation method for flush probes. The order length angle head probes will be taken from the point of furthest insertion, therefore add the required insertion distance to the flush length.
 2) Add 25.4 mm for each inch increase in height of access fitting. Example: add 50.8 mm for a 7.25" fitting instead of a 5.25"

LENGTH CALCULATION: RC STYLE (RETRACTABLE) PROBES

Dimension	Probe style Tubular CEION®				Flush/Angle Head CEION®			
Nominal Length (order code)	18	24	30	36	18	24	30	36
Length overall (mm)	737	887	1037	1187	680	830	980	1130

▲
example

Method: the minimum length of a probe is the sum of the height of the packing assembly (P) and the travel distance to retract the probe so that the valve may be closed (T). T is equal to the sum of the length of insertion into the pipe (I), the wall thickness of the pipe (W) and the height of the branch assembly (H). The value of P is 170 mm for NPT packing glands and 280 mm for flanged packing glands. When the minimum length in millimetres overall is known, the next highest overall length may be found from the table for the insert type to be used, and its nominal length equivalent entered as the length component of the order code. Values I, W & H are site specific variables. For example: if I = 150, W = 15 and H = 250 then T = 415. For an NPT packing P = 170 therefore P+T= 585. If a Flush probe is in use then the next highest table value is 680, and the nominal length vertically above 680 is 18. The sum of values H + T + P gives the minimum clearance above the pipe wall to retract the probe fully. In practice an additional clearance of 100 mm provides working space. Retractor tools may require additional clearance. See data sheet CMEF011 for details of the RC access system.

LENGTH CALCULATION: NPT & BSPT PROBES

You need to know -

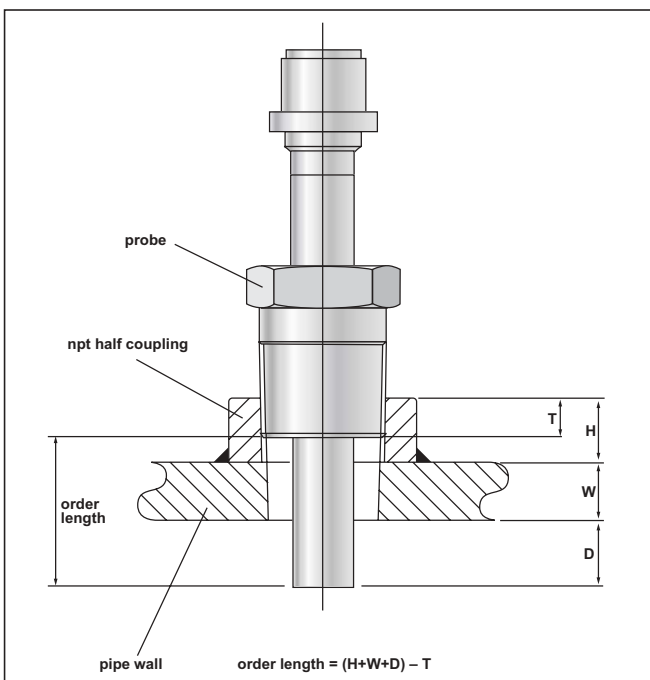

1. The height (H) of the threaded fitting (Threadolet) above the pipe wall in millimetres
2. The wall thickness (W) of the pipe in millimetres
3. The distance (D) that the tip of the probe is to extend beyond the pipe wall into the line - in millimetres.

Look up the thread make-up distance (T) for the probe model you have selected in the attached table (p. 4)

Calculate: $(H+W+D) - T = Order\ Length$. Once you have calculated the Order Length, refer to the table to find either:

1. A Standard fixed length probe that is close enough in length to meet the requirement.
2. A Standard adjustable length probe with an insertion length that exceeds the Order Length required (see note below on minimum insertion lengths).

In either case, if you find that the Standard length probe will meet the requirement, insert the letters **STD** into the product code section for length.

If the Standard length does not meet your requirement, insert the calculated length in millimetres into the product code - remembering to use a 3 digit whole number e.g.: 098. See back page for Product Code Guide.

PRODUCT CODES FOR STANDARD CEION PROBES

CP															
CEION® Probe	M	6 pin probe with plug in module	Mounting		Length		Style			Total element Thickness		Element material*		Accessory	
E	6 pin probe: configured from 'M' type extension adaptor or PC		AC	High-pressure 2" access ftg.	Insert required order length in mm (3 digits) above	FL	Flush epoxy seal 32mm dia.	020	0.020" (0.5mm)	A07	Carbon steel	None	*For other materials options consult Cormon sales	00	None
						AF	Adjustable flush epoxy seal 32mm dia.	040	0.040" (1mm)						
						IA	Angled head epoxy seal 32mm dia.	080	0.080" (2mm)						
						FC	Flush ceramic Standard	160	0.160" (4mm)						
						FH	Flush ceramic High Temperature								
						IC	Angled head ceramic Standard								
			RC	Retractable (%")	12 12" nominal Insertion 18 18" nominal Insertion 24 24" nominal Insertion 30 30" nominal Insertion 36 36" nominal Insertion	FL	Flush epoxy seal 32mm dia.	020	0.020" (0.5mm)	A07	Carbon steel	None	*For other materials options consult Cormon sales	00	None
						FJ	Flush epoxy seal 23mm dia.	040	0.040" (1mm)						
						FC	Flush ceramic Standard 32mm dia.	080	0.080" (2mm)						
						FH	Flush ceramic High Temperature 32mm dia.	160	0.160" (4mm)						
						FK	Flush ceramic Standard 25.4mm dia.								
						HK	Flush ceramic High Temperature 25.4mm dia.								
	Insert required order length (2 digits) above		IC	Angled head ceramic Standard 32mm.			A06	Carbon steel	00	None	VS	Velocity shield			
			IH	Angled head ceramic High Temperature 32mm dia.											
			IK	Angled head ceramic Standard 25.4mm.											
			IJ	Angled head ceramic High Temperature 25.4mm dia.											
			IN	Angled head epoxy sealed 23mm											
			TW	Tubular all welded	020	0.020" (0.5mm)									
TH	Tubular all welded high temperature	040	0.040" (1mm)												

REMEMBER to order the matching adapter for each CEION® probe required

CP															
CEION® probe	M	6 pin probe with plug in module	Mounting type		Mounting size		Style			Total element Thickness		Length		Element material*	
E	6 pin probe: configured from 'M' type extension adaptor or PC		FN	Fixed NPT	05	¾" mounting thread and lab style	FJ	Flush epoxy seal 23mm dia.	020	0.020" (0.5mm)	STD- Standard length	A07	Carbon steel	*For other materials options consult Cormon sales	
			FB	Fixed BSPT			FK	Flush ceramic Standard 25.4mm dia.	040	0.040" (1mm)					
			AN	Adjustable NPT	10	1" mounting thread and lab style	HK	Flush ceramic High Temperature 25.4mm dia.	080	0.080" (2mm)					
			AB	Adjustable BSPT			IK	Angled head ceramic Standard 25.4mm dia.	60	0.160" (4mm)					
			LO	Lab style - no thread mounting			IJ	Angled head High Temperature 25.4mm dia.							
							N	Angled head epoxy sealed 23mm							

Fixed NPT and BSPT probes - order length data & dimensions

THREAD SIZE	PROBE TYPE	LENGTH FIX/ADJ (2)	LENGTH OVERALL (1)	BODY DIA.	ORDER LENGTH= LENGTH BELOW THREAD (1)	NPT			BSPT		
						THREAD MAKE UP "T"	MAX.LENGTH BELOW TOP OF THREAD	MINIMUM INSERTION (3)	THREAD MAKE UP "T"	MAX.LENGTH BELOW TOP OF THREAD	MINIMUM INSERTION (3)
¾"	Tubular	F & A	460	19	325	14	339	125	16	341	125
1"	Tubular	F & A	460	19	325	16	341	125	19	344	125
	Flush/angle head	ADJ	215	19	130	16	146	55	19	149	55

- (1) Order lengths shown are standard - use "STD" in product code or calculate other length in mm
- (2) Codes: F = fixed length ADJ = adjustable length swagelock F & A = available in fixed and adjustable styles
- (3) Minimum insertion = shortest order length for fixed probes or least insertion for adjustable