

LABORATORY, NPT & BSPT PROBES ER & LPR - FIXED INSTALLATION FIXED & ADJUSTABLE INSERTION LENGTHS

cormon

CMEP017.1

This selection of corrosion monitoring probes covers a complete range of electrical resistance (ER) and linear polarisation (LPR) probes in low and medium pressure configurations. These probes are for fixed installation, and cannot be installed or changed in pressurised systems without shut-down.

LABORATORY PROBES

The simple 'Lab' probe is used for a variety of bench top and low pressure tasks. It has no threaded mounting, but is suitable for use with laboratory glass compression fittings and rubber bung insertions. The standard model probes are epoxy sealed with stainless steel bodies and are suitable for service at up to 150°C and 100 psi. Other body and seal materials are available on order.

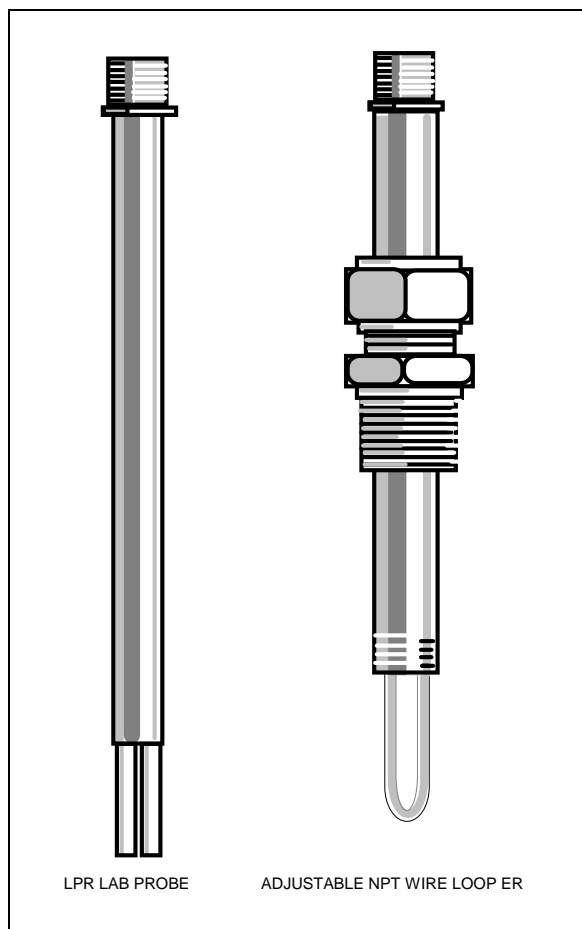

The simple 'Lab' probe is used for a variety of bench top and low pressure tasks. It has no threaded mounting, but is suitable for use with laboratory glass compression fittings and rubber bung insertions. The standard model probes are epoxy sealed with stainless steel bodies and are suitable for service at up to 150°C and 100 psi. Other body and seal materials are available on order.

NPT & BSPT FIXED LENGTH PROBES

Probes with a fixed insertion length below the NPT or BSPT mounting thread, used for a variety of industrial corrosion monitoring tasks and with pressurised test rigs or side streams. Suitable for interruptable and batch processes or locations where temporary isolation is available for installation and retrieval. The NPT and BSPT thread configurations require only a simple thredolet type fitting on the target pipework or vessel. Body material 316ss, seals are epoxy or glass according to type.

NPT & BSPT ADJUSTABLE LENGTH PROBES

Similar in most respects to fixed length probes, with the added benefit of a variable insertion length through the addition of a swagelock type compression fitting at the mounting. Ideal for applications where the equipment may be moved between locations with different insertion requirements due to variation in pipe diameter, wall thickness etc.

INSTRUMENT CONNECTIONS

All probes in this series are fitted with a 6 pin mil-spec connector C5015 which is compatible with all Cormon instrumentation and many other instruments. The F & A series probe connectors are stainless steel with gold plated pins and threaded shells. Lab probes (L series) have threaded alloy shells.

CORMON LTD
CORROSION
MONITORING
SYSTEMS

Riverbank Business Centre
Old Shoreham Road
Shoreham-by-sea
West Sussex BN43 5FL
Phone: +44(0)1273 441168
Fax: +44(0)1273 441169
Email: sales@cormon.com

Website: www.cormon.com

BS EN ISO 9001 Registered (BSI: Q5877)



CALCULATING PROBE LENGTHS FOR NPT & BSPT PROBES

You need to know -

1. The height (H) of the threaded fitting (thredolet) above the pipe wall in millimetres
2. The wall thickness (W) of the pipe in millimetres
3. The distance (D) that the tip of the probe is to extend beyond the pipe wall into the line - in millimetres.

Look up the thread make-up distance (T) for the probe model you have selected in the attached table. (The ER & LPR probe selection data sheets provide helpful information on techniques and probe types)

Calculate: (H+W+D) - T = Order Length

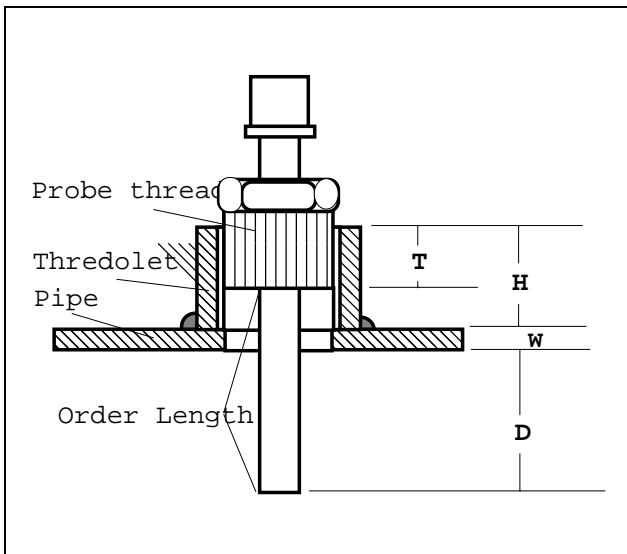

Once you have calculated the Order Length, refer to the table to find either:

1. A Standard fixed length probe that is close enough in length to meet the requirement.
2. A Standard adjustable length probe with an insertion length that exceeds the Order Length required (see note below on minimum insertion

lengths).

In either case, if you find that the Standard length probe will meet the requirement, insert the letters **STD** into the product code section for length.

If the Standard length does not meet your requirement, insert the calculated length in millimetres into the product code - remembering to use a 3 digit whole number e.g.: 098. See back page for Product Code Guide.

Please note: It is not possible to order probes shorter than the minimum length for each type given in the table. In the case of adjustable probes the minimum length and the order length define the lower and upper limits of the possible insertion. For example: a Standard 1" NPT tubular probe with adjustable length has a possible insertion range between 125mm and 325mm below the probe thread.

PRESSURE/TEMPERATURE RATINGS FOR NPT & BSPT PROBES

Glass Seals	260°C	3-4000 psi (usually limited by thread connection)
Epoxy Seals	200°C	1500 psi
Delrin	90°C	2000 psi

If you don't see the combination of style and materials that you need for a particular application, please contact our sales office - we can usually help.

ACCESSORIES - We can supply mounting thredolets in all sizes and most materials, as well as extension cables and replacement electrodes for LPR probes. Replacement electrode product codes are:

GMA			
L	Replacement elements for projecting style probes	S2 - Standard 2 electrode set S3 - Standard 3 electrode set R2 - Reduced 3 electrode set R3 - Reduced 3 electrode set (sets complete with O rings)	A06 Carbon steel B03 316 stainless steel See codes list for other options

Related data sheets:

Material Codes List MD.0149 ER Probe Guide GL.003 LPR Probe Guide GL.005

Instrumentation Data Sheets:

Portable ER/LPR CMEI.004 Data Logging ER/LPR CMEI.006
Externally powered DCU Transmitter CMEI.008
On-line Multi Channel CMEI.005

All available by fax from +44 (0) 1273 441169

CMEP0172

FIXED PROBES - LAB, NPT AND BSPT PROBES - ORDER LENGTH DATA & DIMENSIONS

THREAD SIZE	PROBE TYPE	LENGTH FIX/ADJ (3)	LENGTH OVERALL (2)	BODY DIA.	LENGTH BELOW THREAD (2)	NPT			BSPT		
						THREAD MAKE-UP "T"	MAX. LENGTH BELOW TOP OF THREAD	MINIMUM INSERTION	THREAD MAKE-UP "T"	MAX. LENGTH BELOW TOP OF THREAD	MINIMUM INSERTION
LAB No Thread	LOOP		310	19							
	TUBULAR		430	19							
	FLUSH ER		330	19							
	LPR 2/3 PROJ.		370	19							
	LPR 2/3 FLUSH		370	19							
1/2"	LOOP	F	210	16	85	13	98		15	100	
3/4"	LOOP	F & A	225	19	130	14	144	65	16	146	65
	TUBULAR	F & A	460	19	325	14	339	125	16	341	125
	FLUSH ER	ADJ	215	19	130	14	144	25	16	146	25
	(1) LPR 2/3 PROJ.	F & A	255	19	165	14	179	65	16	181	65
	LPR 2/3 FLUSH	ADJ	255	19	130	14	144	65	16	146	65
1"	LOOP	F & A	225	19	130	16	146	65	19	149	65
	TUBULAR	F & A	460	19	325	16	341	125	19	344	125
	FLUSH ER	ADJ	215	19	130	16	146	25	19	149	25
	(1) LPR 2/3 PROJ.	F & A	255	19	165	16	181	65	19	184	65
	LPR 2/3 FLUSH	ADJ	255	19	130	16	146	65	19	149	65
1 1/2"	LOOP	F	225	19	130	17	147	65	21	151	65
	TUBULAR	F	460	19	325	17	342	125	21	346	125
	FLUSH ER	F	215	19	130	17	147	25	21	151	25
	(1) LPR 2/3 PROJ.	F	255	19	165	17	182	65	21	186	65
	LPR 2/3 FLUSH	F	255	19	130	17	147	65	21	151	65
2"	LOOP	F	225	19	130	18	143	65	26	156	65
	TUBULAR	F	460	19	325	18	343	125	26	351	125
	FLUSH ER	F	215	19	130	18	148	25	26	156	25
	(1) LPR 2/3 PROJ.	F	255	19	165	18	183	65	26	191	65
	LPR 2/3 FLUSH	F	255	19	130	18	143	65	26	156	65

(1)	LENGTHS ARE FOR STANDARD CORMON ELECTRODES - FOR REDUCED TYPE SUBTRACT 006
(2)	ORDER LENGTHS SHOWN BOLD IN BOLD BOXES ARE STANDARD - USE "STD" IN PRODUCT CODE OR CALCULATE OTHER LENGTH IN MM
(3)	CODES: F = FIXED LENGTH ADJ = ADJUSTABLE LENGTH SWAGELOCK F & A = AVAILABLE IN FIXED AND ADJUSTABLE STYLES ADJ STYLE 1 1/2" AND 2" ONLY AVAILABLE TO SPECIAL ORDER
(4)	MINIMUM INSERTION = SHORTEST ORDER LENGTH FOR FIXED PROBES OR LEAST INSERTION FOR ADJUSTABLE

P E R									
Probe	Mounting	Thread Type	Thread Size	Element	Element Size	Length	Element	Accessory	
Electrical Resistance	F -Fixed A -Adjustable	N - NPT B - BSPT	05 - ¾" 10 - 1" 15 - 1 ½" 20 - 2"	WL - Wire Loop (glass)	40 - 0.040" 80 - 0.080"	STD - Standard Length (see table)	A06 - Carbon steel A07 - Carbon steel for Flush probes	00 - without shield VS - with velocity shield	
	L - Lab Probe	O - No thread	05 - ¾"						
PER & PPR probes All 1 ½" & 2" probes are fixed length. (Adjustable only to special order)	PER & PPR probes ¾" & 1" Flush probes are only available in adjustable configuration.	All probe bodies are 316 Stainless Stl. - contact our sales office for alternatives Lab probes are 19 mm dia.	Wire Loop probes are also available in ½" NPT & BSPT fixed length only Use order code 01	WT - Tube Loop (glass)	04 - 0.004" 08 - 0.008"	For other lengths calculate and add millimetre insertion length as required	See material codes for other options	Shields are standard for loop types except Lab probes & optional for tubulars. Not required on Flush	
				TL - Tubular 4" (glass) TS -Tubular 2" (glass)	10 - 0.010" 20 - 0.020"				
				FL - Flush epoxy FG - Flush glass	03 - 0.003" 10 - 0.010" 20 - 0.020" (03 glass only)				

**PRODUCT
CODE GUIDE**

P P R									
Probe	Mounting	Thread Type	Thread Size	Electrode Type	Electrode Configuration	Length	Element Material		
Linear Polarisation Resistance	F -Fixed A -Adjustable L - Lab Probe	N - NPT B - BSPT O - No thread - Lab probe	05 - ¾" 10 - 1" 15 - 1 ½" 20 - 2"	PE - Projecting replaceable (glass)	S2 -Standard 2 electrode S3 -Standard 3 electrode R2 -Reduced 2 electrode R3 -Reduced 3 electrode	STD - Standard Length see table	000 - No electrode A06 - Carbon steel		
	See notes above on availability of adjustable length mountings & body materials.	Electrode areas: PES2 & 3 = 7.86 cm ² PER2 & 3 = 5.00 cm ² FLS2 & 3 = 0.30 cm ²	PE studs are M3 for Standard and 4-40 UNC for Reduced						